

Source Four[®]



User Manual

Production Dates: September 2004 - Present

Copyright © 2008 Electronic Theatre Controls, Inc.
All Rights reserved.
Product information and specifications subject to change.
Part Number: **7060M1200-06.01** Rev C
Released: 2010-01

Picking# 7060M1001-C

Table of Contents

Basic Assembly	1
Fixture information	2
Replacing the HPL Lamp	4
Adjustments	5
Centering lamp and adjusting the field	5
Focusing the beam	5
Shaping the beam	6
Rotating the barrel assembly	7
Adjusting the C-clamp	7
Adjusting the yoke position	8
Cleaning Lens and Reflector	9
Cleaning 14°, 19°, 26°, 36°, 50°, 70°, 90° and all EDLT glass lenses	9
Cleaning 5° and 10° polymer lenses	9
Cleaning the reflector	10

ETC®, Emphasis®, Expression®, Insight™, Imagine™, Focus™, Express™, Unison®, Obsession® II, ETCNet2™, EDMX™, Source Four®, Revolution®, Sensor®, and WYSILink™ are either registered trademarks or trademarks of Electronic Theatre Controls, Inc. in the United States and other countries.

All other trademarks, both marked and not marked, are the property of their respective owners.

Basic Assembly

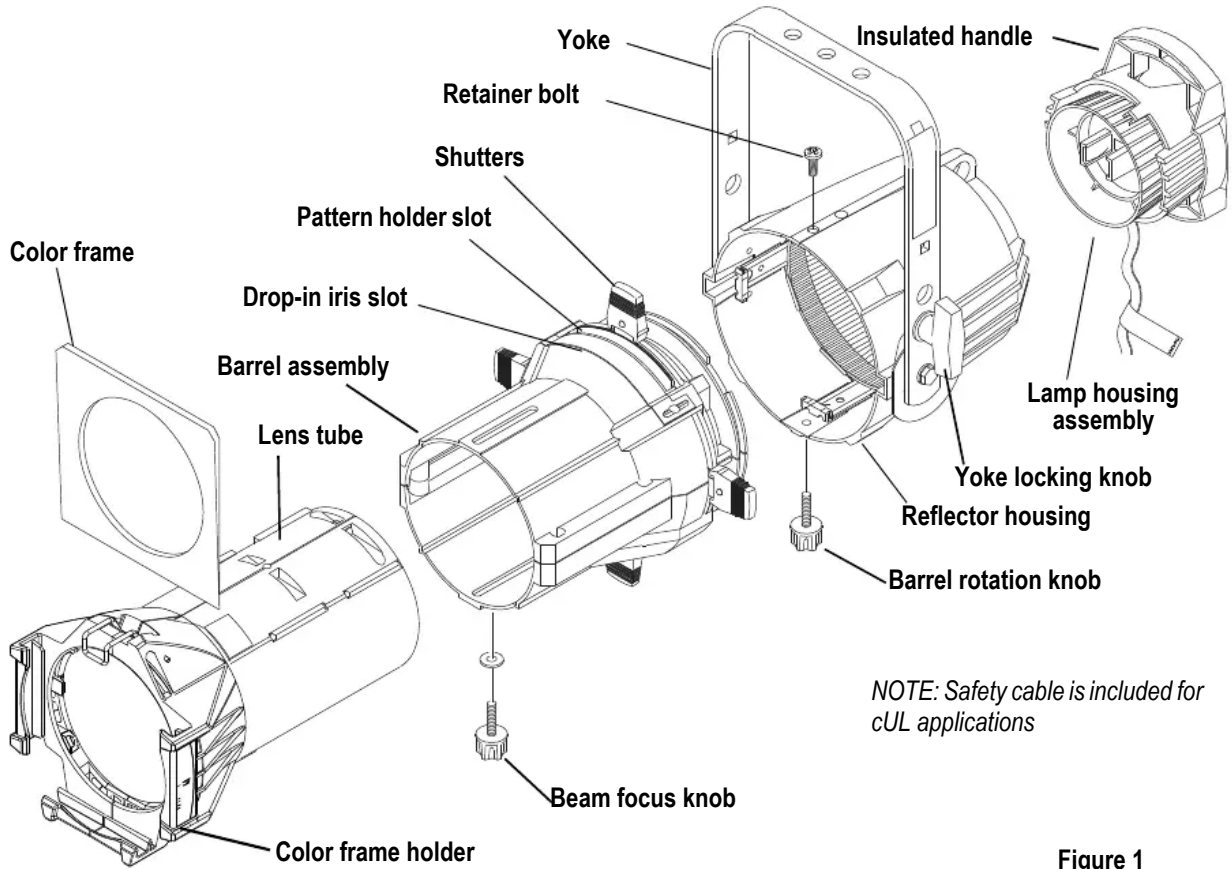

WARNING:

Please note the following safety warnings before use:

Do not mount the fixture on or near combustible surfaces.

Do not operate the fixture without a lens installed.

Always hang the fixture with the color frame retaining clip in the locked position.

Fixture information

HPL lamp table



CAUTION: Do not use lamps other than the HPL in Source Four fixtures. *Use of lamps other than HPL will void UL/cUL safety compliance and your warranty.*

Lamp code	Watts	Volts	Initial	Lumen	Color	temp.	Average rated life
HPL 780/77* 750	77	22,950	3,250°K	300			hours
HPL 550/77* 550	77	16,170	3,250°K	300			hours
HPL 550/77X* 550	77	12,160	3,050°K	2000			hours
HPL 750/115 750	115	21,900	3,250°K	300			hours
HPL 750/115X 750	115	16,400	3,050°K	1500			hours
HPL 575/115 575	115	16,520	3,250°K	300			hours
HPL 575/115X 575	115	12,360	3,050°K	2000			hours
HPL 375/115 375	115	10,540	3,250°K	300			hours
HPL 375/115X 375	115	8,000	3,050°K	1000			hours
HPL 750/120 750	120	21,900	3,250°K	300			hours
HPL 750/120X 750	130	16,400	3,050°K	1500			hours
HPL 575/120 575	120	16,520	3,250°K	300			hours
HPL 575/120X 575	120	12,360	3,050°K	2000			hours
HPL 750/230 750	230	19,750	3,200°K	300			hours
HPL 750/230X 750	230	15,600	3,050°K	1500			hours
HPL 575/230 575	230	14,900	3,200°K	400			hours
HPL 575/230X 575	230	11,780	3,050°K	1500			hours
HPL 375/230X 375	230	7,250	3,000°K	1000			hours
HPL 750/240 750	240	19,750	3,200°K	300			hours
HPL 750/240X 750	240	15,600	3,050°K	1500			hours
HPL 575/240 575	240	14,900	3,050°K	400			hours
HPL 575/240X 575	240	11,780	3,050°K	1500			hours
HPL 375/240X 375	240	7,250	3,000°K	1000			hours

* To be used with ETC Dimmer Doubler™

Color frame holder

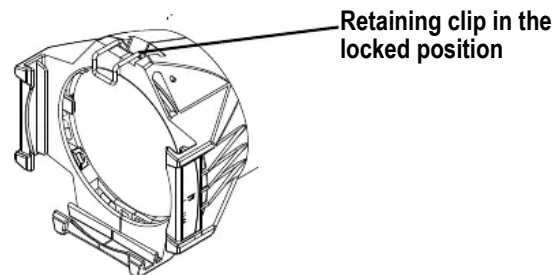

Figure 2

The color frame holder is equipped with a spring-loaded retaining clip that prevents color frames and accessories from falling out. See [Figure 2](#).



WARNING: *Make sure all color frame accessories are locked in position with the retaining clip before hanging the Source Four fixture.*

Step 1: Release the retaining clip by pushing it sideways while gently pulling backwards.

Step 2: Insert the color frame.

Step 3: Lock the retaining clip by pushing sideways while gently pushing forward.



Note:

The performance of saturated colors may be less than desirable in any theatrical lighting fixture, especially when equipped with a 750w lamp. For best results, always use high-quality color media rated for high-temperature use.

ETC's optional Conical Gel Extender, part # 7060A1048, will provide maximum color media life. For 14° lens tubes, use part # PSF1029. Gel Extenders are not recommended for 70° and 90° lens tubes due to the extremely wide-angle beam.

A variety of heat shield products is also available from many color media manufacturers. Follow the manufacturer's instructions for the use of these products.

For maximum gel life with specific lens tubes, refer to the tables below.

Lens Tube	Soft Focus Back (Lamp "flat")	Sharp Focus (Lamp "cosine")	Soft Focus Forward (Lamp "peak")	Soft Focus Forward (Lamp "cosine")
14°	worse good	best good		
70°	best good	worse good		
90°	best good	good worse		
19°	worse better	better not applicable		
26°	worse better	better not applicable		
36°	better better	worse not applicable		
50°	worse better	better not applicable		

ED Lens Tube	Soft Focus Back (Lamp "flat")	Sharp Focus (Lamp "cosine")	Soft Focus Forward (Lamp "peak")	Soft Focus Forward (Lamp "cosine")
19°	worse better	better not applicable		
26°	better better	worse not applicable		
36°	better better	worse not applicable		
50°	better better	worse not applicable		

Replacing the HPL Lamp

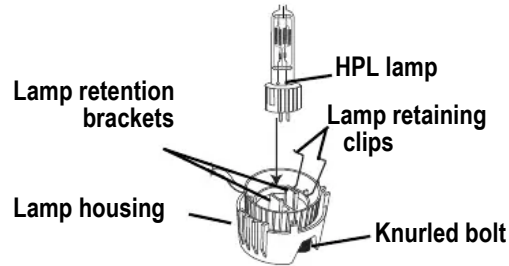

Figure 3

A lamp must be installed before you use the fixture.



Note: Verify that the HPL lamp you intend to install is suitable for your facility's voltage; 115-, 120-, 230-, and 240-volt HPL lamps are available. See [HPL lamp table, page 2](#). Operating HPL lamps above their rated voltage reduces lamp life and can cause premature lamp failure.



WARNING: Let the lamp cool before replacing.

Step 1: Disconnect power to the Source Four before installing the lamp.

Step 2: Loosen the knurled bolt on the back of the lamp housing and pull the housing out.

Step 3: Holding by the base, remove the HPL lamp from its box.



CAUTION: Use caution when installing or replacing any lamp. When installing/replacing lamp, be sure to point the lamp away from your face and away from others before inserting it firmly into the assembly. This may prevent injuries if the lamp should break.

INCORRECT

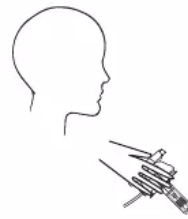

CORRECT



Note: To avoid premature lamp failure, do not touch the lamp glass. If you do, clean it carefully with isopropyl alcohol and a clean lint-free cloth. Allow to dry before operation.

Step 4: Align the flat sides of the lamp base with the retention brackets on either side of the socket as shown in [Figure 3](#).

Step 5: Push down on the lamp base until the lamp seats firmly. When properly installed, the top of the lamp's base will be even with the top edges of the retention brackets.



CAUTION: Improperly installed lamps cause premature lamp failure and socket problems.

Step 6: Press lamp retaining clip across lamp base to secure.

Step 7: Reinstall the lamp housing by aligning the bolt hole and tightening the knurled bolt.

Adjustments

Centering lamp and adjusting the field

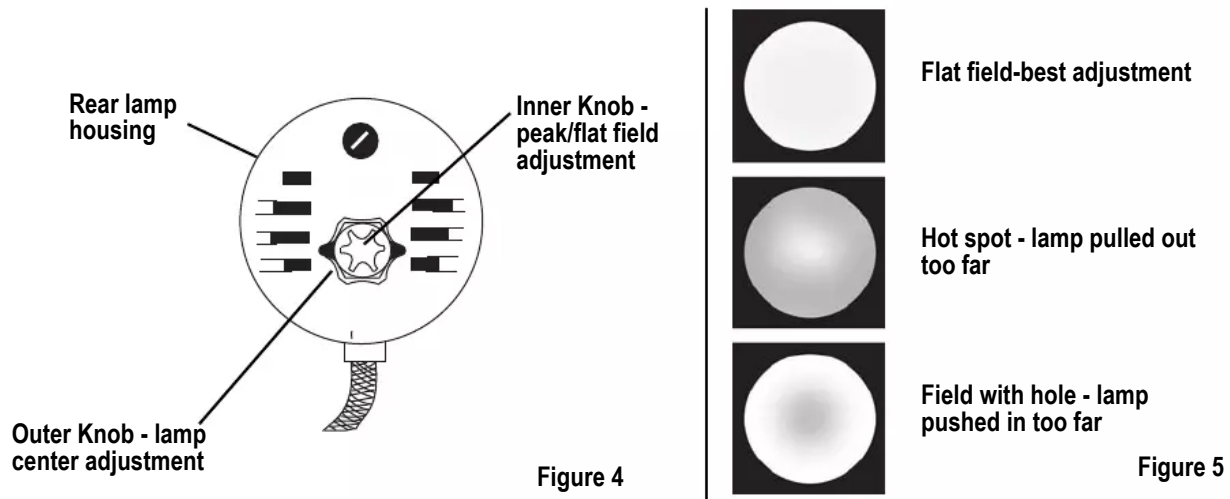

The two concentric knobs located on the lamp housing allow you to align the lamp and adjust its field. See [Figure 4](#). The outer knob centers the lamp within the reflector. The inner knob adjusts the lamp's field.

Step 1: Turn on the Source Four and aim it at a flat surface. Adjust the barrel to create a hard edge.

Step 2: Unlock and loosen the outer knob by turning it counterclockwise.

Step 3: Gently move the outer knob from side to side and up and down until the lamp is centered within the reflector.

Step 4: Once the lamp is centered, turn the outer knob clockwise to lock it in place.

Step 5: Finally, turn the inner knob either clockwise or counterclockwise to achieve an optimum flat field. See [Figure 5](#).

Focusing the beam

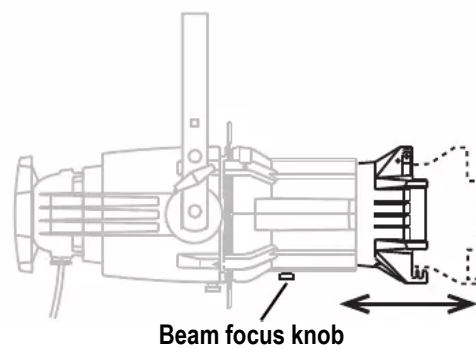

Step 1: Loosen the beam focus knob located under the barrel as shown in [Figure 6](#).

Step 2: Slide the lens tube forward or backward to achieve the desired beam edge.

Step 3: Once the fixture is focused, tighten the beam focus knob.

Shaping the beam

The beam can be shaped using the shutters (see [Figure 1](#)), a pattern, an optional drop-in iris, or by rotating the barrel.

Pattern Projection

The pattern holder slot is on the top side of the barrel and in front of the shutters. It accommodates **A-size**, **B-size** and glass pattern holders (see [Figure 7](#)).

A-Size Pattern holder:
holds 3" diameter patterns

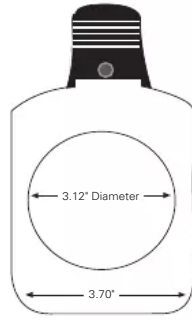

B-Size Pattern holder:
holds 2.5" and 2.75" diameter patterns

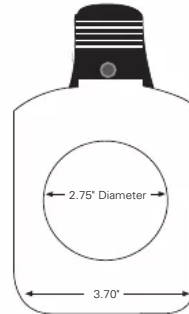

Figure 7



Note:

Because the Source Four aperture is 3 inches wide, ETC recommends using A-size patterns for maximum pattern effectiveness.



Note:

Enhanced Definition Lens Tubes (EDLT) provide for a crisper pattern projection.

Use an optional donut in the accessory holder to enhance pattern projection. Donut diameter range should be 2.5" to 2.75".

Drop-In Iris Slot

Drop-in iris slot

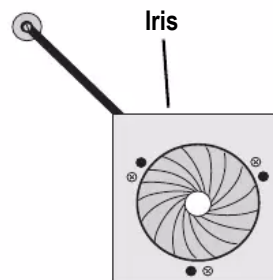
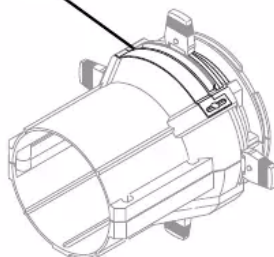

Figure 8

The drop-in iris slot is located on the top of the barrel and in front of the pattern holder slot. It accommodates either a drop-in iris or a motorized pattern device. When the slot is not in use, a small sheet metal cover secured with two Phillips screws prevents light leakage (see [Figure 8](#)).

Step 1: Use a Phillips screwdriver to loosen the screws on the drop-in iris slot cover. Do not remove screws.

Step 2: Slide the cover completely forward to expose the slot.

Step 3: Insert the iris or motorized pattern device. For an iris, install the flat side toward the shutters and make sure the iris handle extends from the slot.

Step 4: Slide the slot cover back toward the shutters until it meets the iris handle. Leave enough space to move the iris handle.

Step 5: Secure the drop-in iris slot cover by tightening the screws.

Rotating the barrel assembly

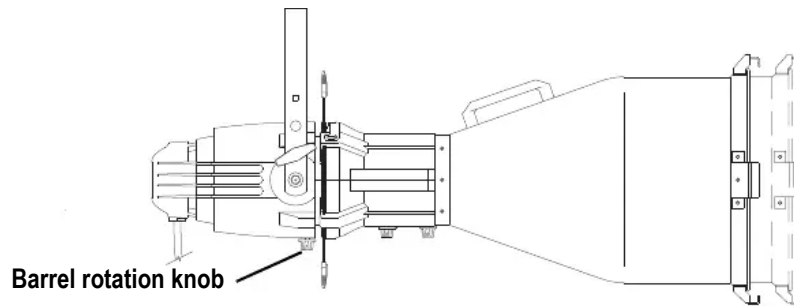

Figure 9

Step 1: Loosen the barrel rotation knob directly behind the shutters on the underside of the reflector housing (see [Figure 9](#)). **Do not** remove the barrel rotation knob.

Step 2: Rotate the barrel to the desired position (up to 25° in either direction from the centered position).

Step 3: Once the barrel is positioned, tighten the barrel's rotation knob to lock it in place.

Adjusting the C-clamp

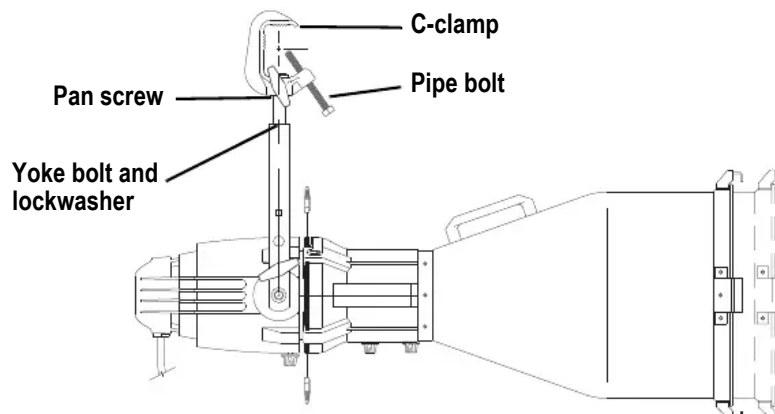

Figure 10

The C-clamp attaches the fixture to the mounting pipe and allows you to adjust the position of the fixture once it is mounted (see [Figure 10](#)).

Step 1: Tightly fasten the C-clamp to the yoke with the provided yoke bolt and lock washer.

Step 2: Place the C-clamp on mounting pipe, then tighten the pipe bolt to secure it.

Step 3: Loosen the C-clamp pan screw and rotate the yoke to the desired position.

Step 4: Tighten the pan screw to lock the fixture.



CAUTION: *Tighten C-clamp pipe bolt to 15-20 ft./lbs. (approximately finger tight plus up to one-quarter turn). Do not exceed 25 ft./lbs. Do not use excessive force.*
Tighten the yoke pivot bolt to 5-10 ft./lbs. (approximately finger tight plus up to one-eighth turn). Do not exceed 15 ft./lbs. Do not use excessive force.

Adjusting the yoke position

The Source Four provides multi-positioning capabilities within its yoke for overall fixture height and angle.

Setting the fixture height within the yoke

The Source Four has a two-position yoke for modifying the overall height in which the fixture is mounted (see [Figure 11](#)). To change the height position, perform the following steps.

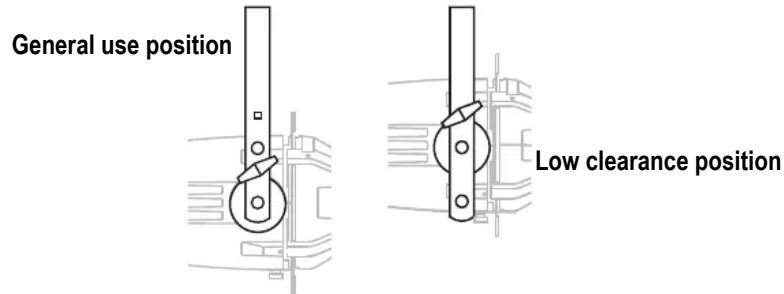

Figure 11

Step 1: Remove the yoke locking knobs, washers, and hex bolts from either side of the fixture.

Step 2: Raise or lower the fixture to the desired position within the yoke.

Step 3: Reinstall the yoke's hex bolts, washers, and locking knobs.

Step 4: Tighten the yoke knobs to secure in position.

Setting the angle within the yoke

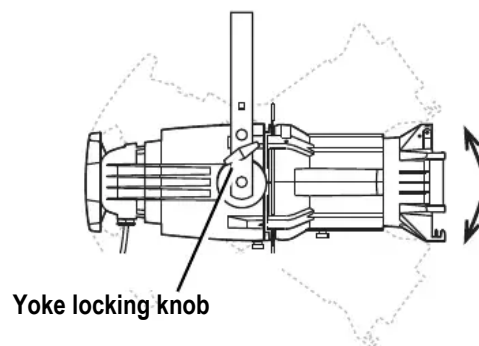

Figure 12

Step 1: Loosen the yoke locking knobs (see [Figure 12](#)). **Do not** remove them.

Step 2: Tilt the fixture to the desired position.

Step 3: Tighten the yoke locking knobs to secure in position.

Cleaning Lens and Reflector



WARNING: *Do not use ammonia-based or other harsh commercial cleaners. Clean lens and reflector only as directed.*

Commercially available glass cleaning agents should be avoided as they may contain ammonia, other harsh chemical detergents or abrasive agents. These cleaners may damage the glass surface and the Anti-Reflective coatings. Do not immerse or soak the glass in any cleaning solution.

Replace lenses if they contain visible damage (cracks or deep scratches) that may impair their effectiveness.

Cleaning 14°, 19°, 26°, 36°, 50°, 70°, 90° and all EDLT glass lenses

Step 1: Remove the beam focus knob and retainer bolt from the barrel (see [Figure 1](#)). Remove the lens tube from the barrel.



Note: *To clean the inside of lenses, it is necessary to remove the lenses from the lens tube for cleaning. Instruction for removing the lens can be found in the Source Four Assembly Guide available for download at our website: www.etconnect.com.*

Step 2: Remove dust with a blast of oil-free air or wipe with a clean, lint-free cloth. Isopropyl alcohol, distilled water or a 50%-50% mixture of each can be used to clean the glass surface.

Step 3: Slide the lens tube back into the barrel with the color frame retaining clip on top. Reinstall the beam focus knob and retainer bolt.

Cleaning 5° and 10° polymer lenses

To quickly clean the lenses, remove dust with a blast of oil-free air. If this is not sufficient, follow these steps.



CAUTION: *Handle polymer lenses by their edges only. Never rub anything dry on a polymer lens.*

Step 1: Remove the beam focus knob at the bottom of the barrel (see [Figure 1](#)). Remove the lens tube from the barrel.

Step 2: Use a Phillips screwdriver to remove the brackets that hold the lens in place. Remove the lens from the tube.

Step 3: Dip the lens in a clean isopropyl alcohol/water mixture (9 parts water to 1 part isopropyl alcohol).

Step 4: Use a soft moistened nylon bristle brush to wash the lens' smooth side in a linear (non-circular) motion.

Step 5: Use the same brush to lightly wash the lens' ridged side by following its ridges.

Step 6: Dip the lens in a clean isopropyl alcohol/water mixture (9 parts water to 1 part isopropyl alcohol).

Step 7: Dry the smooth and ridged surfaces with an air gun. Make sure the air flow moves liquid away from you.

Step 8: Inspect the lens for dirt. Repeat steps 3-7 if necessary.

Step 9: Set the lens back in the lens tube with the ridged side facing the front of the tube. Reinstall the lens brackets.

Step 10: Slide the lens tube back into the barrel with gel frame retainer on top. Reinstall beam focus knob.

Cleaning the reflector



WARNING: *Unplug the fixture before attempting to clean the reflector.*

To quickly clean the reflector, remove the lens tube and clean the dust from the reflector with a blast of oil-free air. You may also wipe the reflector with a clean lint-free cloth. If either method is not sufficient, follow these steps.

Step 1: To protect the lamp housing during cleaning, remove the lamp housing by loosening the knurled bolt and pulling the housing straight out. See [Figure 3](#).

Step 2: Remove the barrel rotation knob located at the bottom of the barrel (see [Figure 1](#)). Use a Phillips screwdriver to remove the retainer bolt located on top of the reflector housing.

Step 3: Rotate the barrel 45° in either direction. Carefully remove the barrel from the reflector housing.

Step 4: Remove dust with a blast of oil-free air or wipe with a clean, lint-free cloth. Isopropyl alcohol, distilled water or a 50%-50% mixture of each can be used to clean the glass surface.

Step 5: Insert the barrel into the reflector housing with the iris/pattern slot on top. Align the triangles on both parts.

Step 6: While gently pressing in, rotate the barrel 45° clockwise until it sets into position, then rotate the barrel counterclockwise 45°. The barrel should be firmly attached and the triangles should be aligned.

Step 7: Reinstall the barrel rotation knob and tighten the retainer bolt.

Step 8: Reinstall the lamp housing and tighten the knurled bolt.



Corporate Headquarters ■ 3031 Pleasant View Road, P.O. Box 620979, Middleton, Wisconsin 53562-0979 USA ■ Tel +608 831 4116 ■ Fax +608 836 1736
London, UK ■ Unit 26-28, Victoria Industrial Estate, Victoria Road, London W3 6UU, UK ■ Tel +44 (0)20 8896 1000 ■ Fax +44 (0)20 8896 2000
Rome, IT ■ Via Ennio Quirino Visconti, 11, 00193 Rome, Italy ■ Tel +39 (06) 32 111 683 ■ Fax +39 (06) 32 656 990
Holzkirchen, DE ■ Ohmstrasse 3, 83607 Holzkirchen, Germany ■ Tel +49 (80 24) 47 00-0 ■ Fax +49 (80 24) 47 00-3 00
Hong Kong ■ Rm 1801, 18/F, Tower 1 Phase 1, Enterprise Square, 9 Sheung Yuet Road, Kowloon Bay, Kowloon, Hong Kong ■ Tel +852 2799 1220 ■ Fax +852 2799 9325
Service: (Americas) service@etcconnect.com ■ (UK) service@etceurope.com ■ (DE) techserv-hoki@etcconnect.com ■ (Asia) service@etcasia.com
Web: www.etcconnect.com ■ Copyright © 2008 ETC. All Rights Reserved. ■ Product information and specifications subject to change.
7060M1200-06.01 ■ Rev C ■ Released 2010-01